

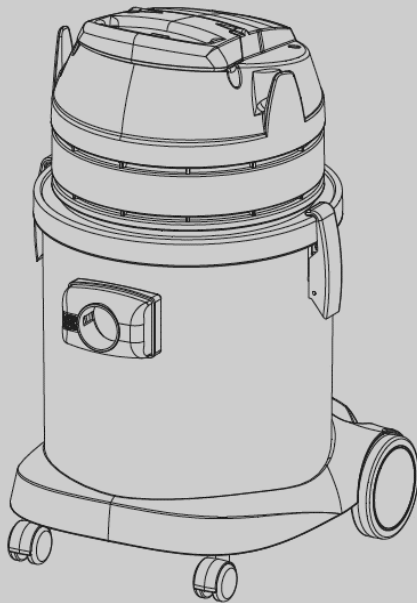

V-WD-27

Wet/Dry Vacuum

Parts Manual



Model Part No.:

1244330 V-WD-27 [220-240V EU]
1244331 V-WD-27 [220-240V UK]
1244333 V-WD-27 [220-240V ANZ]
1244332 V-WD-27 [220-240V CN]
1244334 V-WD-27 [100V JP]

TennantTrue® Parts

Walo Hygiëne en Reinigingssystemen B.V.
0187-605374
welkom@walo.nl
www.walo.nl



9018762
Rev. 00 (03-2019)

Only use TENNANT Company supplied or equivalent parts.
Parts and supplies may be ordered online, by phone or from any Tennant or Nobles
Authorized Service Center or Distributor.

Before Ordering any parts or supplies, be sure to have the machine model number and
serial number available.

Walo Hygiëne en Reinigingssystemen B.V.
0187-605374
welkom@walo.nl
www.walo.nl



TABLE OF CONTENTS

HEAD ASSEMBLY (EU/UK/CN/ANZ 220-240V MODELS)	4
HEAD ASSEMBLY (JAPAN 100V MODEL)	8
MAIN FILTER ASSEMBLY	10
TANK ASSEMBLY	11
TROLLEY ASSEMBLY	11
ACCESSORY TOOLS	12
OPTIONAL DRY VACUUM ACCESSORIES	13
LABEL KIT	13
ELECTRICAL DIAGRAM	14

RECOMMENDED SPARE PARTS LIST

VACUUM BAGS AND FILTERS	
KTRIO5847	BAG, VACUUM, PAPER [1 PKG = 10 BAGS]
KTRIO5848	BAG, VACUUM, MICROFIBER [1 PKG = 10 BAGS]
KTRIO5853	FILTER KIT, VACUUM [220-240V MODEL]
KTRIO5849	FILTER KIT, VACUUM [100V MODEL]
KTRIO5800	FILTER KIT, VACUUM, PRE-FILTER
CLEANING TOOL ACCESSORIES	
1064248	HANDLE, VACUUM HOSE W/ REG, Ø36 MM
KTRIO5819	HOSE ASSY, VACUUM
1064249	WAND SET, EXTN, PLST, 36MM [2 PCS]
KTRIO5680	TOOL KIT, VACUUM [CREVICE TOOL, ROUND BRUSH TOOL AND FURNITURE TOOL]
KTRIO5818	TOOL, FLOOR, DRY
1064333	TOOL, FLOOR, WET
KTRIO5924	TOOL, CREVICE, 35 cm, 36 mm [OPTIONAL]
KTRIO5925	TOOL, CREVICE, 60 cm, 36 mm [OPTIONAL]
OPTIONAL HEPA FILTER	
KTRIO5808	FILTER KIT, CARTRIDGE, HEPA W/RING & GASKET
KTRIO5801	FILTER, CARTRIDGE, HEPA
KTRIO5839	RING, FASTENER, PLASTIC
GENERAL MAINTENANCE PARTS	
1021687	CASTER KIT, VACUUM [QTY 2]
KTRIO5679	WHEEL KIT, REAR
KTRIO5678	LATCH KIT, VACUUM [QTY 2]
1021646	SWITCH, ON/OFF
KTRIO5850	FLOAT KIT, BASKET
KTRIO5674	CORD KIT, POWER, 220-240V [EU]
KTRIO5683	CORD KIT, POWER, 220-240V [UK]
KTRIO5695	CORD KIT, POWER, 220-240V [ANZ]
KTRIO5706	CORD KIT, POWER, 220-240V [CN]
KTRIO5696	CORD KIT, POWER, 100V [JP]
KTRIO5675	MOTOR KIT, VACUUM, 1000W, 220-240VAC
KTRIO5709	MOTOR KIT, VACUUM, 1000W, 100VAC [JPN]
KTRIO5676	GASKET KIT, MOTOR 220-240VAC
KTRIO5613	GASKET KIT, MOTOR 100VAC [JPN]

HEAD ASSEMBLY (EU/UK/CN/ANZ 220-240V MODELS)

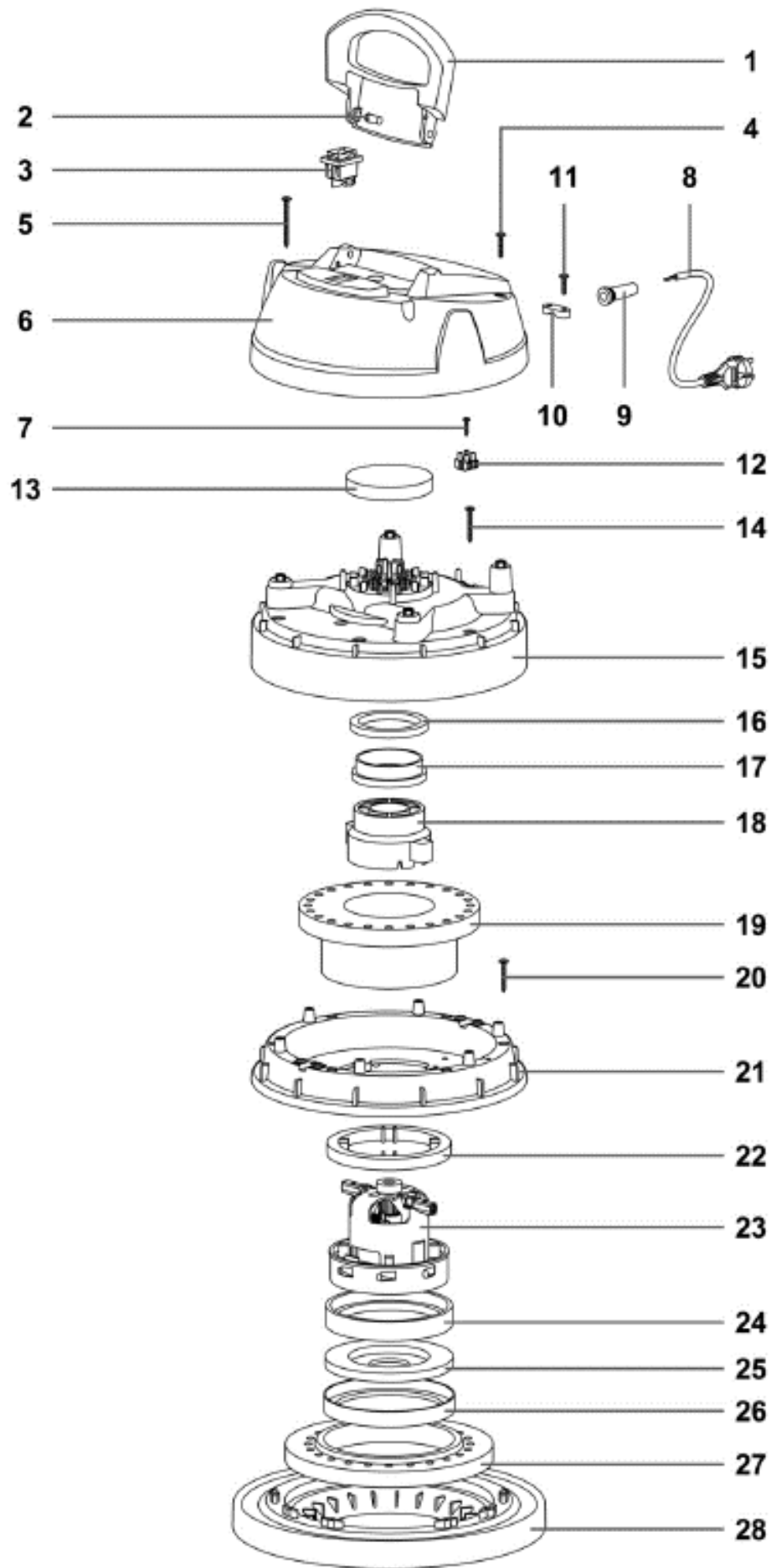

HEAD ASSEMBLY (EU/UK/CN/ANZ 220-240V MODELS)

Code	Part No.	Description	QTY
▽	KTRIO5723	HOUSING ASSY, POWER, HEAD [V-WD-27 EU]	1
▽	KTRIO5724	HOUSING ASSY, POWER, HEAD [V-WD-27 UK]	1
▽	KTRIO5725	HOUSING ASSY, POWER, HEAD [V-WD-27 CN]	1
▽	KTRIO5726	HOUSING ASSY, POWER, HEAD [V-WD-27 ANZ]	1
▲ ▽	KTRIO5672	COVER KIT, VACUUM, TEAL [V-WD-27]	1
▲ ▲ 1	N/A	HANDLE VEGAS GRIGIO 5500	1
▲ ▲ 2	N/A	HANDLE PIN VEGAS	2
▲ 3	1021646	SWITCH, ON/OFF	1
▲ ▲ 4	N/A	SCREW PFU TMT PHL 5X25 ZN BLACK	2
▲ ▲ 5	1021710	SCREW PAT TMT PHL 5X55 BLACK	2
▲ ▲ 6	N/A	COVER VEGAS 500 BL-TEN	1
▲ ▽	KTRIO5673	TERMINAL KIT, W/WIRES [220-240V]	1
▲ ▲ 7	N/A	SCREW VITE TC PZ 4,2X16 ZN NERA	1
▲ ▲ 12	1021629	TERMINAL, BLOCK	1
▲ ▽	KTRIO5674	CORD KIT, POWER, 220-240V [EU]	1
▲ ▲ 8	N/A	ELECTRIC CORD 2X1 MT.8,5	1
▲ ▲ 9	1021625	LEAD	1
▲ ▲ 10	1021626	BLOCK, STRAINRELIEF	1
▲ ▲ 11	1021628	SCREW PFU TMT PHL 5X20 BLACK	1
▲ ▽	KTRIO5683	CORD KIT, POWER, 220-240V [UK]	1
▲ ▲ 8	N/A	ELECTRIC CORD 2X1 MT.8,5 GB BLACK	1
▲ ▲ 9	1021625	LEAD	1
▲ ▲ 10	1021626	BLOCK, STRAINRELIEF	1
▲ ▲ 11	1021628	SCREW PFU TMT PHL 5X20 BLACK	1
▲ ▽	KTRIO5706	CORD KIT, POWER 220-240V [CN]	1
▲ ▲ 8	N/A	ELECTRIC CORD 2X1 MT.8,5 CHINA	1
▲ ▲ 9	1021625	LEAD	1
▲ ▲ 10	1021626	BLOCK, STRAINRELIEF	1
▲ ▲ 11	1021628	SCREW PFU TMT PHL 5X20 BLACK	1
▲ ▽	KTRIO5695	CORD KIT, POWER, 220-240V [ANZ]	1
▲ ▲ 8	N/A	ELECTRIC CORD 2X1 MT.8,5 AUS	1
▲ ▲ 9	1021625	LEAD	1
▲ ▲ 10	1021626	BLOCK, STRAINRELIEF	1
▲ ▲ 11	1021628	SCREW PFU TMT PHL 5X20 BLACK	1
▲ 13	1021647	FILTER	1
▲ 14	1021648	SCREW PAT TMT PHL 5X35 BLACK	6
▲ 15	1021650	LID, MIDDLE, TEAL	1
▲ 16	1021651	WASHER H8 D85X65	1
▲ ▽	KTRIO5675	MOTOR KIT, VACUUM, 1000W, 220-240VAC	1
▲ ▲ 18	N/A	CAP /ADAPTER F/MOT.BYPASS AU	1
▲ ▲ 23	N/A	MOTOR BS282 WL 1000W 220-240	1
▲ ▲ NS	N/A	CAVETTO C.420-GR-FF-FF48	1
▲ ▲ NS	N/A	CAVETTO C.430 MOT-TP GR-FF-FF4.8	1
▲ ▲ NS	N/A	CLAMP (NOT SHOWN)	1

Continued on next page

▽ KIT

▲ INCLUDED IN KIT

N/A = NOT AVAILABLE SEPARATELY - MUST ORDER KIT

HEAD ASSEMBLY (EU/UK/CN/ANZ 220-240V MODELS) - Continued

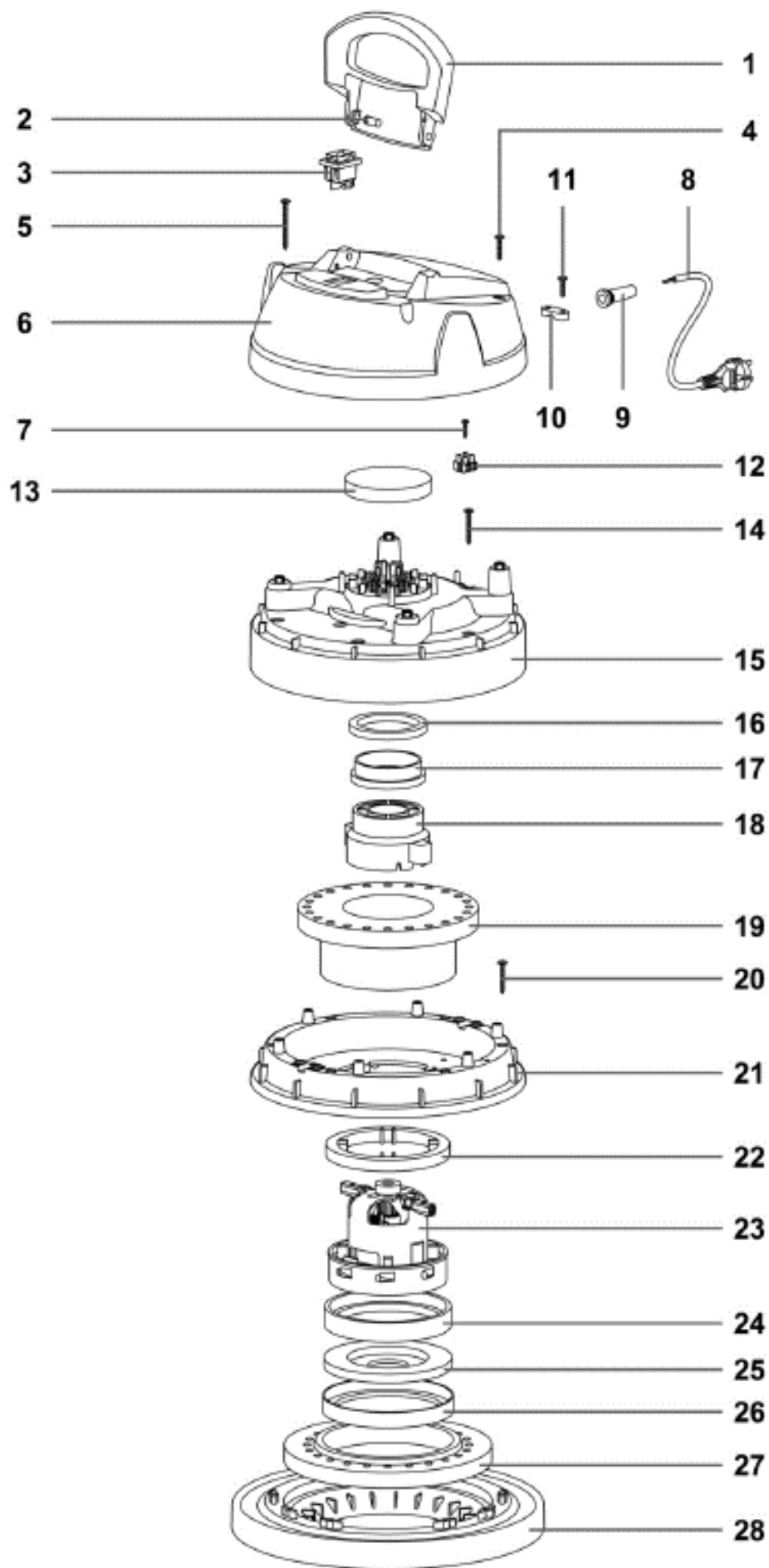

HEAD ASSEMBLY (EU/UK/CN/ANZ 220-240V MODELS) - Continued

Code	Part No.	Description	QTY
▲ ▽	KTRI05676	GASKET KIT, MOTOR 220-240VAC	1
▲ ▲ 17	1021652	SPACER, MOTOR	1
▲ ▲ 19	1021653	DAMPER, SOUND	1
▲ ▲ 22	N/A	"C" GASKET D.130	1
▲ ▲ 24	N/A	L-GASKET D.130 H=9	1
▲ ▲ 25	N/A	OUTDISTANCED SINGLE-STAGE H=13MM	1
▲ ▲ 26	1021657	RING, BOTTOM, MOTOR	1
▲ ▲ 27	1021659	RING, BOTTOM	1
▲ 20	1021648	SCREW PAT TMT PHL 5X35 BLACK	6
▲ 21	N/A	MOTOR FASTENER 08 X MOT.WL BL-TEN	1
▲ 28	N/A	BASE 500 MONOST.W/GASKE GR5500	1
▲ NS	1021628	SCREW PFU TMT PHL 5X20 BLACK	4
▲ NS	N/A	LABEL, SAFETY, READ MANUAL [CE]	1
▲ NS	N/A	LABEL, LOGO, TENNANT	1

▽ KIT

▲ INCLUDED IN KIT

N/A = NOT AVAILABLE SEPARATELY - MUST ORDER KIT

HEAD ASSEMBLY (JAPAN 100V MODEL)

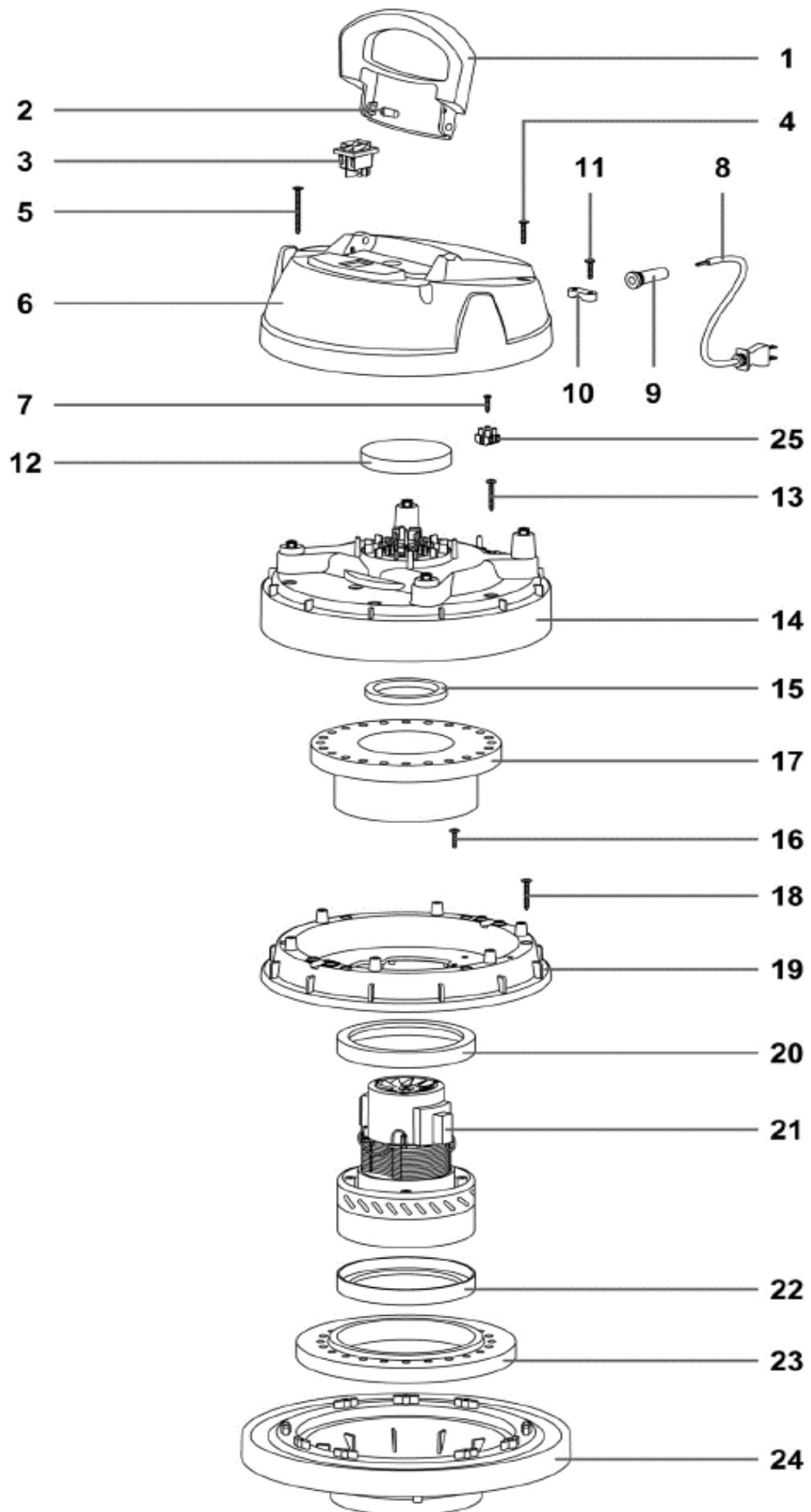

HEAD ASSEMBLY (JAPAN 100V MODEL)

Code	Part No.	Description	QTY
▽	KTRI05727	HOUSING ASSY, POWER, HEAD [V-WD-27 JPN]	1
▲ ▽	KTRI05672	COVER KIT, VACUUM, TEAL [V-WD-27]	1
▲ ▲ 1	N/A	HANDLE VEGAS GRIGIO 5500	1
▲ ▲ 2	N/A	HANDLE PIN VEGAS	2
▲ 3	1021646	SWITCH, ON/OFF	1
▲ ▲ 4	N/A	SCREW PFU TMT PHL 5X25 ZN BLACK	2
▲ ▲ 5	1021710	SCREW PAT TMT PHL 5X55 BLACK	2
▲ ▲ 6	N/A	COVER VEGAS 500 BL-TEN	1
▲ ▽	KTRI05682	TERMINAL KIT, W/WIRES [JPN]	1
▲ ▲ 7	1021717	SCREW VITE TC PZ 4,2X16 ZN NERA	1
▲ ▲ 25	N/A	TERMINAL, BLOCK	1
▲ ▽	KTRI05696	CORD KIT, POWER, 100VAC [JPN]	1
▲ ▲ 8	N/A	ELECTRIC CORD 2X1,25 MT.8,5 JPN	1
▲ ▲ 9	1021625	LEAD	1
▲ ▲ 10	1021626	BLOCK, STRAINRELIEF	1
▲ ▲ 11	1021628	SCREW PFU TMT PHL 5X20 BLACK	1
▲ 12	1021647	FILTER	1
▲ 13	1021648	SCREW PAT TMT PHL 5X35 BLACK	6
▲ 14	1021650	LID, MIDDLE, TEAL	1
▲ 15	1021651	WASHER H8 D85X65	1
▲ ▽	KTRI05709	MOTOR KIT, VACUUM, 1000W, 100VAC [JPN]	1
▲ ▲ 21	N/A	MOTOR BD382 1000W 100 50/60	1
▲ ▲ NS	N/A	CABLAGGIO 40CM MOTORE POKE-IN	1
▲ ▲ NS	N/A	CLAMP (NOT SHOWN)	1
▲ ▽	KTRI05613	GASKET KIT, MOTOR 100VAC [JPN]	1
▲ ▲ 17	1021653	DAMPER, SOUND	1
▲ ▲ 20	1021657	RING, BOTTOM, MOTOR	2
▲ ▲ 22	1021657	RING, BOTTOM, MOTOR	2
▲ ▲ 23	1021659	RING, BOTTOM	1
▲ 16	1021628	SCREW PFU TMT PHL 5X20 BLACK	4
▲ 18	1021648	SCREW PAT TMT PHL 5X35 BLACK	6
▲ 19	N/A	MOTOR FASTNER MOT 100V	1
▲ 24	N/A	BASE 500 GASKE GR5500 MOT 100V	1
▲ NS	N/A	LABEL, SAFETY, READ MANUAL [CE]	1
▲ NS	N/A	LABEL, LOGO, TENNANT	1

▽ KIT

▲ INCLUDED IN KIT

N/A = NOT AVAILABLE SEPARATELY - MUST ORDER KIT

MAIN FILTER ASSEMBLY

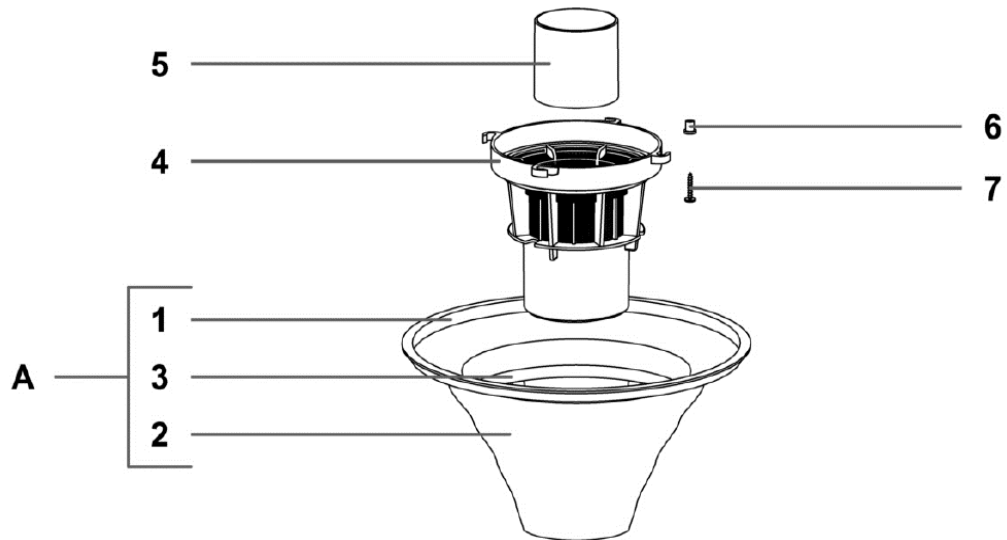

	Code	Part No.	Description	QTY
▽	A	KTRIO5853	FILTER KIT, VACUUM [220-240V MODEL]	1
▲	1	N/A	FILTER RING 500	1
▲	2	N/A	FILTER POLY AN3-500 CON REG H180	1
▲	3	1021668	BASKET, CLOTH, FILTER	1
▽	A	KTR05849	FILTER KIT, VACUUM [100V MODEL]	1
▲	1	N/A	FILTER RING 500	1
▲	2	N/A	FILTER POLY AN3-500 CON REG H230	1
▲	3	1021668	CONICAL BASKET 300	1
▽		KTRIO5850	FLOAT KIT, BASKET	1
▲	4	N/A	NET ANTIFOAM BODY HIGH	1
▲	5	1021666	FLOAT	1
▲	6	1021661	SPACER	4
▲	7	1021663	SCREW PAT TMT PHL 5X25	4

▽ KIT

▲ INCLUDED IN KIT

N/A = NOT AVAILABLE SEPARATELY - MUST ORDER KIT

TANK ASSEMBLY

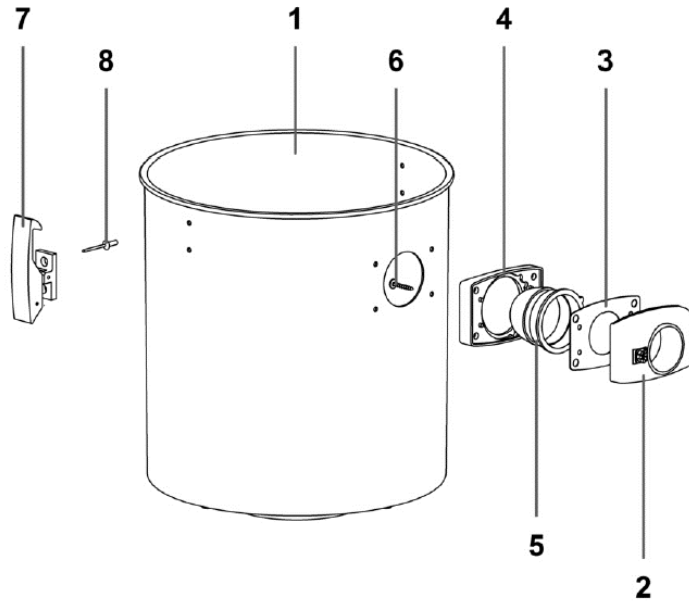

Code	Part No.	Description	QTY
▽	KTRIO5729	TANK KIT, VACUUM [V-WD-27 COMPLETE ASSY]	1
▲ 1	N/A	DRUM PL 500/27W C/Q NE	1
▲ ▽	KTRIO5677	FITTING KIT, HOSE, INLET	1
▲ ▲ 2	N/A	COMP.INLET R155 BLACK W/YELL.SWITCH	1
▲ ▲ 3	1021675	GASKET	1
▲ ▲ 4	N/A	GASKET R 205 BLACK	1
▲ ▲ 5	1021685	INLET, TANK	1
▲ ▲ 6	1021640	SCREW PAT TMT PHL 5X30 BLACK	4
▲ ▽	KTRIO5678	LATCH KIT, VACUUM [QTY 2]	1
▲ ▲ 7	N/A	HOOK PLAST.COMPL. GI-VAC	2
▲ ▲ 8	N/A	RIVET 4,8X17	4
▲ NS	N/A	LABEL, MODEL [V-WD-27]	2

TROLLEY ASSEMBLY

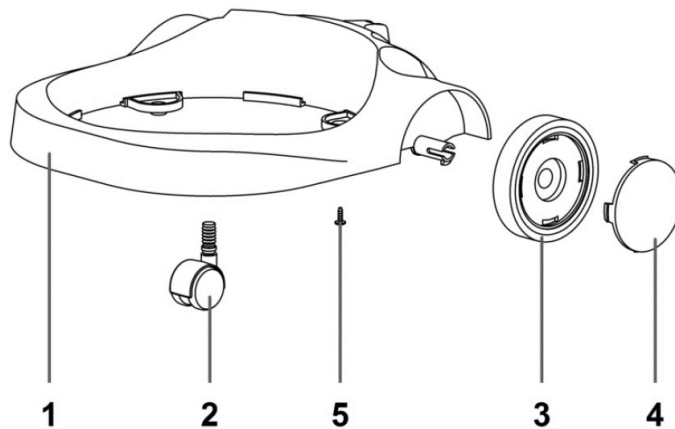

Code	Part No.	Description	QTY
▽	KTRIO5816	TROLLEY KIT, VACUUM [V-WD-27]	1
▲ 1	N/A	TROLLEY BODY 500 VEGAS BL	1
▲ 2	1021687	CASTER, SWIVEL	2
▲ ▽	KTRIO5679	WHEEL KIT, REAR	1
▲ ▲ 3	N/A	WHEEL BODY YES	2
▲ ▲ 4	N/A	WHEEL COVERING YES BLACK	2
▲ 5	1021706	SCREW PAT TMT PHL 5X14 ZN BLACK	4

▽ KIT

▲ INCLUDED IN KIT

N/A = NOT AVAILABLE SEPARATELY - MUST ORDER KIT

ACCESSORY TOOLS

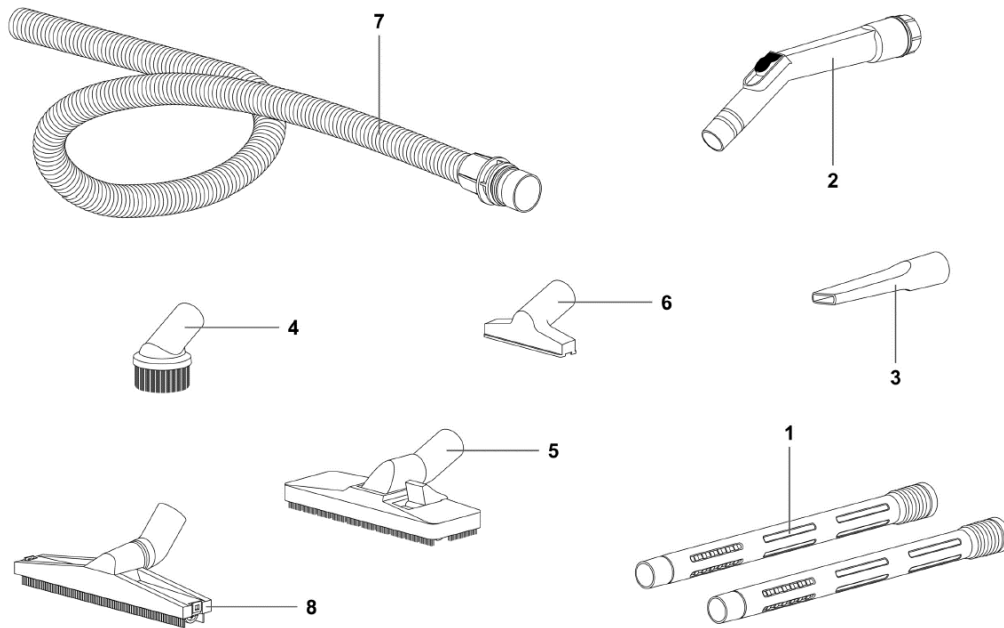

Code	Part No.	Description	QTY
1	KTRIO5785	WAND SET, EXTN, PLST, 36MM [2 PCS]	2
2	1064248	HANDLE, VACUUM HOSE W/ REG, Ø36 MM	1
▽	KTRIO5680	TOOL KIT, VACUUM	1
▲ 3	N/A	TOOL, CREVICE, 36MM	1
▲ 4	N/A	TOOL, BRUSH, ROUND, 36MM	1
▲ 6	N/A	TOOL, SMALL, 36MM	1
5	KTRIO5818	TOOL, FLOOR, DRY	1
7	KTRIO5819	HOSE ASSY, VACUUM	1
8	1064333	TOOL, FLOOR, WET	1

▽ KIT

▲ INCLUDED IN KIT

N/A = NOT AVAILABLE SEPARATELY - MUST ORDER KIT

OPTIONAL DRY VACUUM ACCESSORIES



Code	Part No.	Description	Qty	
1	KTRIO5847	BAG, VACUUM, PAPER [1 PKG = 10 BAGS]	1	
2	KTRIO5848	BAG, VACUUM, MICROFIBER [1 PKG=10 BAGS]	1	
3	KTRIO5800	FILTER, VACUUM, PRE-FILTER	1	
▽	KTRIO5808	FILTER KIT, CARTRIDGE, HEPA W/RING & GASKET	1	
▲	4	KTRIO5801	FILTER, CARTRIDGE, HEPA	1
▲	5	KTRIO5839	RING, FASTENER, PLASTIC	1
▲	6	N/A	GASKET H3	1
7	KTRIO5924	TOOL, CREVICE, 35 cm, 36 mm	1	
8	KTRIO5925	TOOL, CREVICE, 60 cm, 36 mm	1	

▽ KIT

▲ INCLUDED IN KIT

N/A = NOT AVAILABLE SEPARATELY - MUST ORDER KIT

LABEL KIT



Code	Part No.	Description	QTY	
▽	KTRIO5681	LABEL KIT, VACUUM [V-WD-27]	1	
▲	1	N/A	LABEL, LOGO, TENNANT	1
▲	2	N/A	LABEL, SAFETY, READ MANUAL [CE]	1
▲	3	N/A	LABEL, MODEL [V-WD-27]	2

▽ KIT

▲ INCLUDED IN KIT

N/A = NOT AVAILABLE SEPARATELY - MUST ORDER KIT

ELECTRICAL DIAGRAMS

EU/UK/CN/ANZ 220-240V MODELS

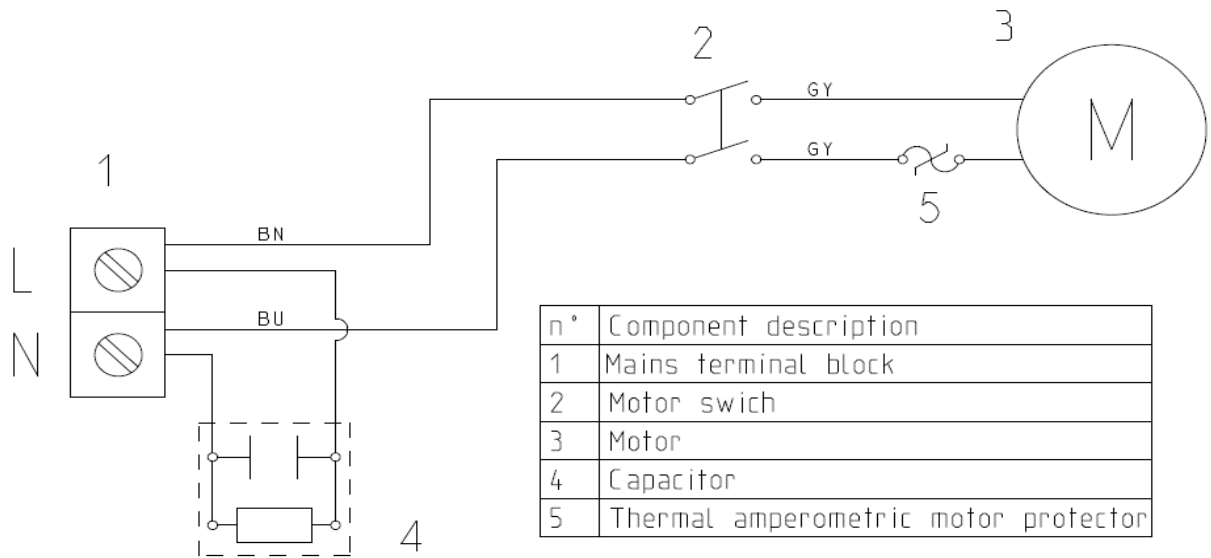

JAPAN 100V MODEL

