

**TENNANT**<sup>®</sup>

# 2370

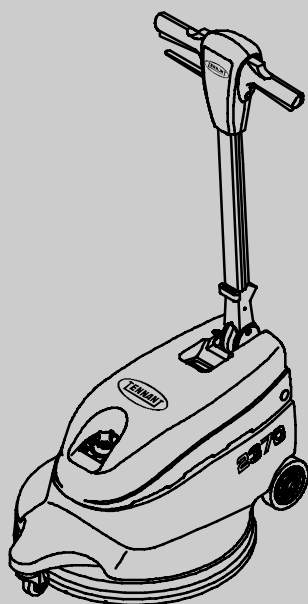

Parts List (EN)  
Ersatzteilliste (DE)  
Liste Des Pièces (FR)  
Onderdelen Lijst (NL)  
Lista De Repuestos (ES)

Model Part No.:  
M23702004 - 230V/50HZ  
M23702094 - 230V/50HZ U.K.  
1010330 - 230V/240V/50HZ  
1010331 - 220V/60HZ



CE

**WALO**  
hygiëne en reinigingssystemen

1010348  
Rev. 01 (02-2006)

# PARTS LIST - ERSATZTEILLISTE - LISTE DES PIÈCES - ONDERDELENLIJST - LISTA DE REPUESTOS

**EN**

This manual is furnished with each new TENNANT 2370. A complete illustrated Parts Lists is supplied with this machine, use this list to order parts. Before ordering parts or supplies, be sure to have your machine model number and serial number handy. Parts and supplies may be ordered by phone or mail from any TENNANT parts and service center, distributor or from any of the TENNANT subsidiaries.

**DE**

Dieses Handbuch wird mit jeder neuen TENNANT 2370 ausgeliefert. Vergewissen Sie sich vor der Bestellung von Ersatzteilen oder Zubehör, daß Sie die Modell- und Seriennummer Ihrer Maschine zur Hand haben. Ersatzteile und Zubehör können Sie telefonisch oder schriftlich bei jedem TENNANT -Ersatzteile- und Kundendienst- Zentrum, bei Ihrem TENNANT- Vertragshändler oder einer der TENNANT-Filialen bestellen.

**FR**

Ce manuel accompagne chaque nouvelle machine TENNANT 2370. Avant de commander des pièces détachées ou des fournitures, veuillez à avoir à portée de la main le numéro de modèle et le numéro de série de votre machine. Vous pouvez commander les pièces détachées et les fournitures par téléphone ou par courrier auprès de tout centre de service après-vente TENNANT, tout distributeur TENNANT agréé ou toute succursale TENNANT.

**NL**

Deze handleiding hoort bij de TENNANT 2370. Zorg ervoor dat u het type- en serienummer van uw machine bij de hand hebt wanneer u een bestelling doorgeeft. U kunt alle benodigde onderdelen en materialen telefonisch of schriftelijk bestellen bij Service Centers, distributeurs of dochterondernemingen van TENNANT.

**ES**

El presente manual acompaña todas las TENNANT Modelo 2370 nuevas. Antes de hacer el pedido de piezas o repuestos, asegúrese de que tenga a mano el número de modelo y el número de serie de la máquina. Puede hacer su pedido de piezas y repuestos por teléfono o por carta a cualquiera de los centros de repuestos y servicio TENNANT, distribuidores o a cualquiera de las sucursales de TENNANT.

## MACHINE DATA - MASCHINEN-DATEN - DONNEES DE LA MACHINE - MACHINEGEGEVENS - DATOS DE LA MÁQUINA

Please fill out at time of installation for future reference.

Bitte halten Sie hier die folgenden Angaben über Ihre Maschine fest, damit Sie diese später nachschlagen können.

Veuillez remplir ce cadre au moment de l'assemblage pour vos besoins futurs.

S.v.p. invullen bij ingebruikname voor toekomstige referentie.

Por favor rellene estos datos en el momento de la instalación para utilizarlos como referencia en el futuro.

Model No.-	Installation Date -	Serial Number-
Modell Nr.-	Datum Inbetriebnahme -	Maschinen-Seriennummer-
No. Modèle-	Date d'installation -	No. Série de la Machine-
Modelnr.-	Datum ingebruikname -	Seriennummer-
Nº Modelo- _____	Fecha de instalación - ___/___/___	Nº de serie de la Máquina - _____

Walo Hygiëne en Reinigingssystemen B.V.  
0187-605374  
welkom@walo.nl  
www.walo.nl



Copyright ©2003, 2006 Tennant Company.

**PARTS LIST - ERSATZTEILLISTE - LISTE DES PIÈCES -  
ONDERDELENLIJST - LISTA DE REPUESTOS**

---

**TABLE OF CONTENTS - INHALTSVERZEICHNIS - SOMMAIRE - INHOUDSOPGAVE - ÍNDICE**

**PARTS LIST - ERSATZTEILLISTE - LISTE DES PIÈCES - ONDERDELENLIJST - LISTA DE REPUESTOS**

<b>HANDLE GROUP</b> .....	<b>4</b>
HEBEL-EINHEIT	
GROUPE POIGNÉE	
HENDELGROEP	
GRUPO DEL ASA	
<b>BASE GROUP</b> .....	<b>6</b>
SOCKELEINHEIT	
GROUPE BASE	
FRAMEGROEP	
GRUPO BASE	
<b>PAD DRIVER GROUP</b> .....	<b>8</b>
PAD ANTIEB GRUPPE	
GROUPE ENTRAINEMENT DU PATIN	
BOENSCHIJF AANDRIJF GROEP	
GRUPO TRANSMISIÓN DE ALMOHADILLA DE LIMPIEZA	
<b>ELECTRICAL DIAGRAM - ELEKTRISCHES SYSTEM - SYSTÈM ÉLECTRIQUE -</b> .....	<b>10</b>
<b>ELEKTRISCH SYSTEEM - ESQUEMA ELÉCTRICO</b>	

PARTS LIST – ERSATZTEILLISTE – LISTE DES PIÈCES –  
ONDERDELENLIJST – LISTA DE REPUESTOS

HANDLE GROUP - HEBEL-EINHEIT - GROUPE POIGNÉE - HENDELGROEP - GRUPO DEL ASA

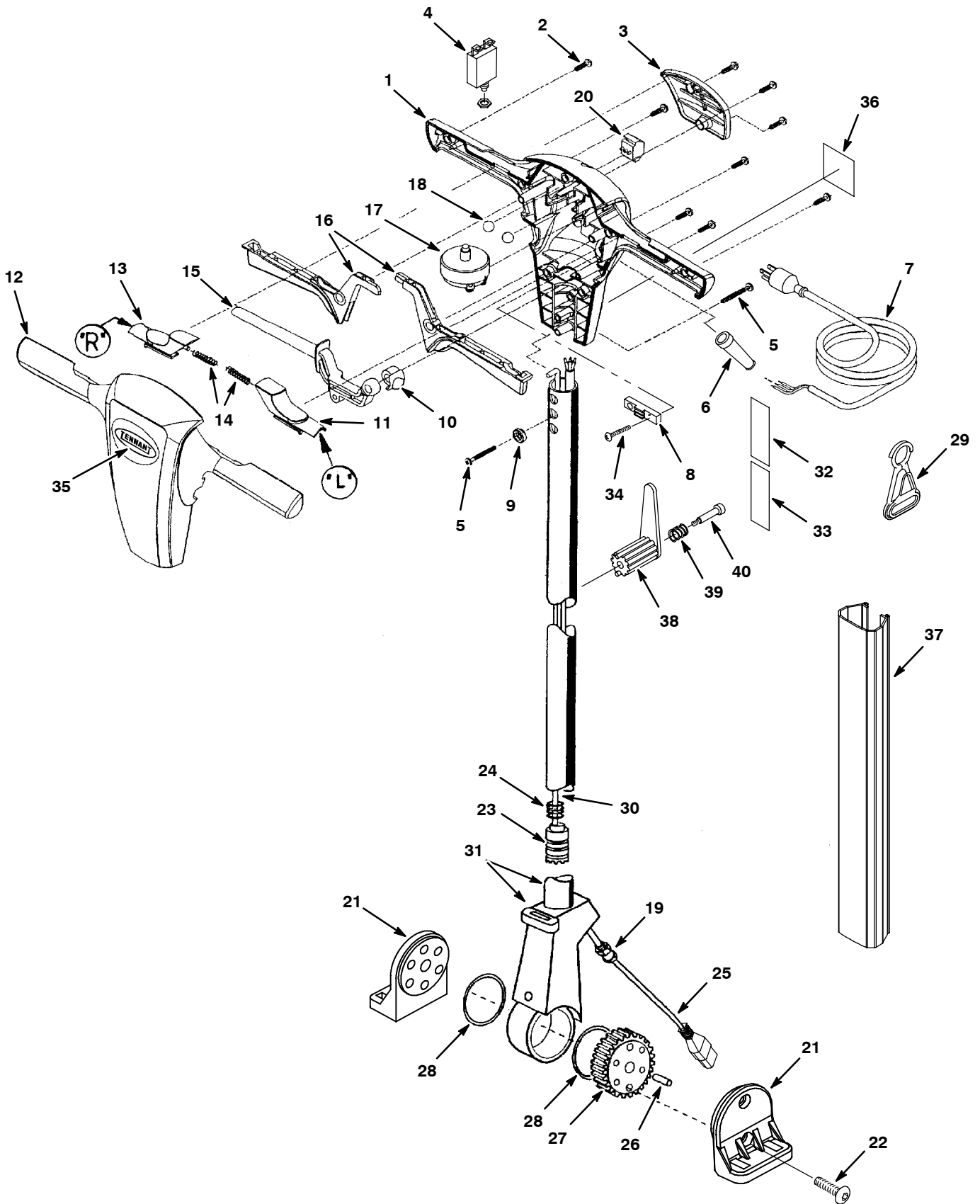

**PARTS LIST – ERSATZTEILLISTE – LISTE DES PIÈCES –  
ONDERDELENLIJST – LISTA DE REPUESTOS**

**HANDLE GROUP - HEBEL-EINHEIT - GROUPE POIGNÉE - HENDELGROEP - GRUPO DEL ASA**

REF	PART #	DESCRIPTION	BEZEICHNUNG	DESIGNATION	OMSCHRIJVING	DESCRIPCIÓN	QTY	
1	613268	HOUSING, HANDLE REAR	GEHÄUSE	BOITIER	HUIS	CAJA	1	
2	801274	SCREW	SCHRAUBE	VIS	SCHROEF	TORNILLO	9	
3	801003	COVER	DECKEL	COUVERCLE	DEKSEL	CUBIERTA	1	
4	1008116	●CIRCUIT BREAKER, 10AMP	SICHERUNGSAUTOM	COUPE-CIRCUIT	ZEKERINGAUTOMT	INTERRUPTOR	1	
5	801247	SCREW	SCHRAUBE	VIS	SCHROEF	TORNILLO	2	
6	801448	GRIP, CORD	KABELHALTER	POIGNEE DE CABLE	SNOERGREEP	SOPORTE DEL CABLE	1	
7	801403	●CORD, POWER 20M	KABEL	CABLE	STROOMKABEL	CABLE	1	
	801453	●CORD, POWER 20M (U.K.)	KABEL	CABLE	STROOMKABEL	CABLE	1	
8	99916617	CLAMP	KLEMMSCHELLE	ATTACHE	KLEM	ABRAZADER	1	
9	99916544	INSERT	EINSATZ	PIÈCE RAPPORTÉE	INZETSTUK	INSERTO	1	
10	1000592	PLUG, LEVER HOLE	STOPFEN	BOUCHON	PLUG	TAPÓN	1	
11	801005	SWITCH, "L"	SCHALTER "L"	INTERRUPTEUR "L"	SCHAKELAAR "L"	INTERRUPTOR "L"	1	
12	613264	HOUSING, HANDLE FRONT	GEHÄUSE	BOITIER	HUIS	CAJA	1	
13	801004	SWITCH, "R"	SCHALTER "R"	INTERRUPTEUR "R"	SCHAKELAAR "R"	INTERRUPTOR "R"	1	
14	801013	SPRING	FEDER	RESSORT	VEER	RESORTE	2	
15	612521	LEVER	HEBEL	LEVIER	HENDEL	PALANCA	1	
16	801006	LEVER	HEBEL	LEVIER	HENDEL	PALANCA	2	
17	99916592	●SWITCH	SCHALTER	INTERRUPTEUR	SCHAKELAAR	INTERRUPTOR	1	
18	801035	BALL	KUGEL	ROTULE	KOGEL	BOLAS	2	
19	99942168	GRIP, CORD	KABELHALTER	POIGNEE DE CABLE	SNOERGREEP	SOPORTE DEL CABLE	1	
20	801052	BLOCK, TERMINAL	ANSCHLUßKLEMME	BORNE	AANSLUITKLEM	TERMINAL	1	
21	613336	SUPPORT, HANDLE	PLATTE	PLAQUE	PLAAT	PLACA	2	
22	99915121	SCREW	SCHRAUBE	VIS	SCHROEF	TORNILLO	4	
23	801259	PUNGER, NOTCHED PIN	TAUCHKOLBEN	PLONGEUR	PLUNJER	ÉMOLO	1	
24	99915228	SPRING	FEDER	RESSORT	VEER	RESORTE	1	
25	1008230	●CORD, HANDLE	KABEL	CABLE	STROOMKABEL	CABLE	1	
26	99918243	PIN	STIFT	GOUPILLE	PEN	PASADOR	2	
27	800495	GEAR, WHEEL	ZAHNRAD	PIGNON ENGRENAGE	TANDWIEL	ENGRANAJE	1	
28	99923586	RING	RING	ANNEAU	RING	ANILLO	2	
29	130176	BELT CLIP, STRAIN-RELIEF (OPTIONAL)	GÜRTELHALTERUNG, SPANNUNGSLÖSER (OPTIONAL)	CEINTURE, DÉTENTE (EN OPTION)	RIEMKLEM, BELASTINGVERMINDERING (OPTIONEEL)	CLIP PARA LA CORREA, LIBERACIÓN DE LA TENSIÓN (OPCIONAL)	1	
30	1000476	ROD, RELEASE	STAB, LÖSEN	TIGE, RELÂCHEMENT	STANG, ONTKOPPELING	VARILLA, LIBERACIÓN	1	
▽	31	1010268	ASM., TUBE W/LABELS	ROHR, GRIFF	TUBE	BUIS	TUBO	1
▲	32	613083	LABEL, WARNING FLAMMABLE	AUFKLEBER	ÉTIQUETTE	LABEL	ADHESIVO	1
▲	33	993852	LABEL, WARNING 230V CORD	AUFKLEBER	ÉTIQUETTE	LABEL	ADHESIVO	1
	34	801449	SCREW	SCHRAUBE	VIS	SCHROEF	TORNILLO	2
35	99918249	LABEL, "TENNANT"	AUFKLEBER	ÉTIQUETTE	LABEL	ADHESIVO	1	
36	578729	LABEL, READ MANUAL	AUFKLEBER	ÉTIQUETTE	LABEL	ADHESIVO	1	
37	1000760	COVER, HANDLE	DECKEL	COUVERCLE	DEKSEL	CUBIERTA	1	
38	603104	HOOK, CORD QUICK-RELEASE	HAKEN	CROCHET	KABELHAAK	GANCHO	1	
39	603108	SPRING	FEDER	RESSORT	VEER	RESORTE	1	
40	140239	SCREW, 3/8X1-3/4 SHOULDER	SCHRAUBE	VIS	SCHROEF	TORNILLO	1	
N/S	1008283	ASM., WIRE BROWN	KABELSATZ	ENSEMBLE DE FIL	DRAADSAMENSTEL	CONJ. DE CABLES	2	
N/S	1008312	ASM., WIRE BLUE	KABELSATZ	ENSEMBLE DE FIL	DRAADSAMENSTEL	CONJ. DE CABLES	1	

▽ ASSEMBLY/BAUGRUPPE/ENSEMBLE/SAMENSTEL/CONJUNTO

▲ INCLUDED IN ASSEMBLY/IM BAUGRUPPE INBEGRIFFEN/Y COMPRIS EN ENSEMBLE/  
BIJ SAMENSTELLING INBEGREPEN/INCLUIDO A CONJUNTA

● RECOMMENDED STOCK ITEM/ EMPFOHLENER VORRATSARTIKEL/ ÉLÉMENTS DE STOCK RECOMMANDÉS/  
AANBEVOLEN ARTIKELN OP VOORRAAD/ PIEZAS RECOMENDADAS EN ALMACÉN

N/S NOT SHOWN/ NICHT ANGEZEIGT/ NON-INDIQUÉ/ NIET AFGEBEELD/ SIN MOSTRAR

**PARTS LIST – ERSATZTEILLISTE – LISTE DES PIÈCES –  
ONDERDELENLIJST – LISTA DE REPUESTOS**

**BASE GROUP - SOCKELEINHEIT - GROUPE BASE - FRAMEGROEP - GRUPO BASE**

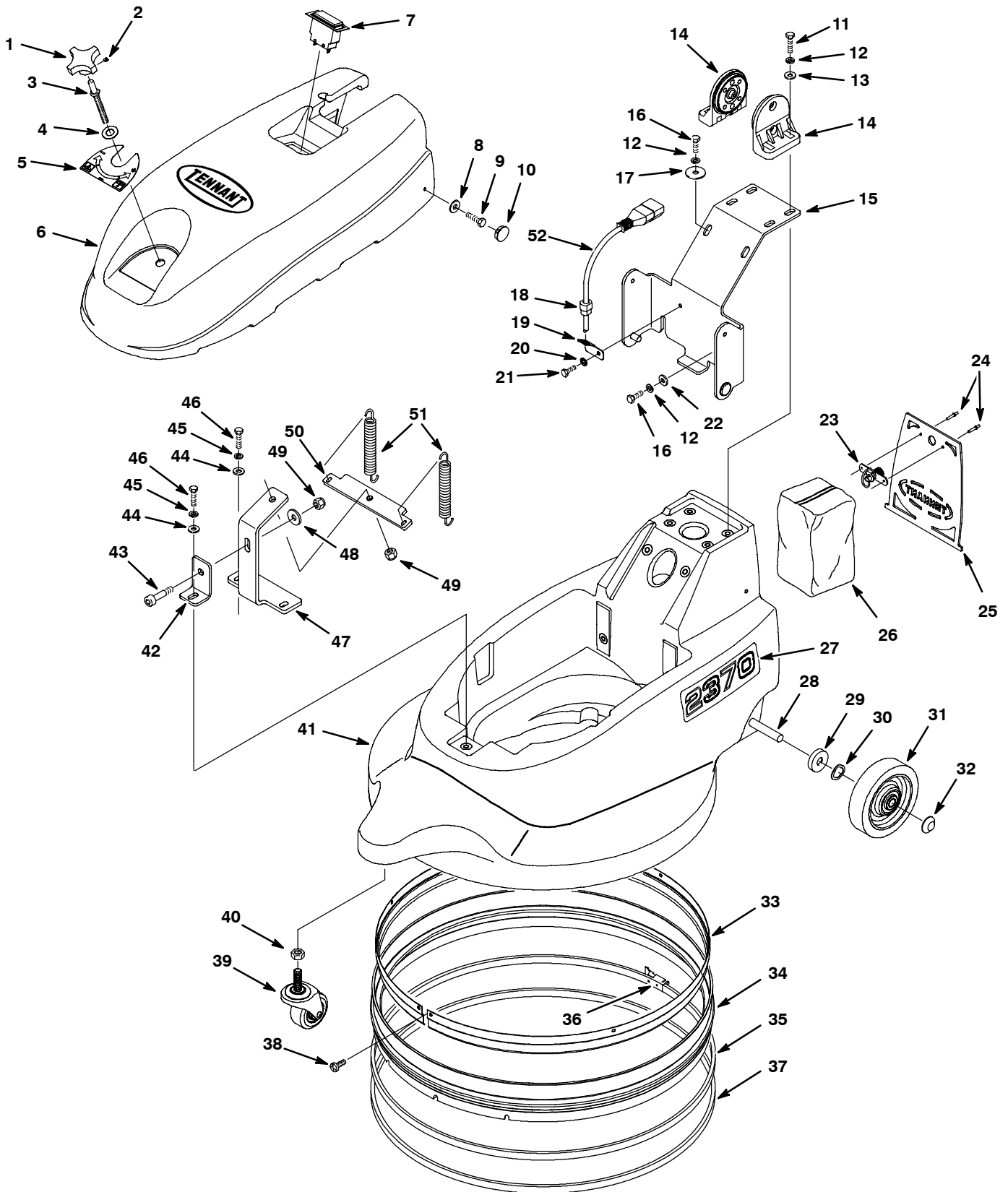

**PARTS LIST – ERSATZTEILLISTE – LISTE DES PIÈCES –  
ONDERDELENLIJST – LISTA DE REPUESTOS**

**BASE GROUP - SOCKELEINHEIT - GROUPE BASE - FRAMEGROEP - GRUPO BASE**

REF	PART #	DESCRIPTION	BEZEICHNUNG	DESIGNATION	OMSCHRIJVING	DESCRIPCIÓN	QTY	
∇	1	600974	●KNOB, W/SET SCREW	KNOPF	BOUTON	KNOP	PERILLA	1
▲	2	140894	SCREW, SET 10-32X1/4	SCHRAUBE	VIS DE PRESSION	BEVESTIGINGSSCHROEF	TORNILLO DE FIJACIÓN	1
	3	611865	STUD, PRESSURE ADJUSTMENT	STIFTSCHRAUBE	GOUJON	TAPEIND	ESPARRAGO	1
	4	20536-2	WASHER, FLT 0.47B 1.19D .03 NY	FLACHSCHEIBE	RONDELLE	VLAKRING	ARANDELA	1
	5	1008755	LABEL, PRESSURE ADJ.	AUFKLEBER	ÉTIQUETTE	LABEL	ADHESIVO	1
	6	1007333	COVER, MOTOR TEAL	DECKEL	COUVERCLE	DEKSEL	CUBIERTA	1
	7	1008006	●GAUGE, PAD PRESSURE	AMPERE METER	JAUGE	METER	CALIBRADOR	1
	8	140000	WASHER, FLAT 1/4	FLACHSCHEIBE	RONDELLE	VLAKRING	ARANDELA	2
	9	15678	SCREW, HEX M6X1.0X16	SCHRAUBE	VIS	SCHROEF	TORNILLO	2
	10	130175	PLUG, DOME .75OD BLACK	STOPFEN	BOUCHON	PLUG	TAPÓN	2
	11	09023	SCREW, HEX M8X1.25X35	SCHRAUBE	VIS	SCHROEF	TORNILLO	4
	12	140015	WASHER, LOCK SPLIT	SCHEIBE	RONDELLE	SLUITRING	ARANDELA	8
	13	140027	WASHER, FLAT .31	FLACHSCHEIBE	RONDELLE	VLAKRING	ARANDELA	4
	14	613336	SUPPORT, HANDLE	PLATTE	PLAQUE	PLAAT	PLACA	2
	15	1007690	BRACKET, HANDLE	HALTER	SUPPORT	STEUN	SOPORTE	1
	16	15675	SCREW, HEX M8X1.25X16	SCHRAUBE	VIS	SCHROEF	TORNILLO	4
	17	140014	WASHER, 5/16X1-1/2 FNDR	SCHEIBE	RONDELLE	RING	ARANDELA	1
	18	605395	STRAIN RELIEF, CORD	KABEL	CABLE	KABEL	CABLE	1
	19	1007299	BRACKET, STRAIN RELIEF	HALTER	SUPPORT	STEUN	SOPORTE	1
	20	140052	WASHER, 1/4 LOCK	SCHEIBE	RONDELLE	SLUITRING	ARANDELA	1
	21	200031432	SCREW, M6X10	SCHRAUBE	VIS	SCHROEF	TORNILLO	1
	22	140027	WASHER, FLAT .31	FLACHSCHEIBE	RONDELLE	VLAKRING	ARANDELA	3
	23	140962	LATCH, SPRING KNURLED	SPERRE	LOQUET	SLUITING	PESTILLO	1
	24	609264	RIVET, BLIND	NIET	RIVET	POPNAGEL	REMACHE	2
	25	1000670	COVER, BAG	TUR	PORTE	DEUR	PUERTA	1
	26	1000617	●FILTER, BAG CLOTH (STANDARD)	STAUBEUTEL	SAC A POUSSIÈRE	STOFZAK, STOF	BOLSO, TELA	1
		1001923	●FILTER, BAG PAPER 10/PK (OPTIONAL)	STAUBEUTEL (OPTIONAL)	SAC À POUSSIÈRE (EN OPTION)	STOFZUIGERZAK (OPTIONEEL)	BOLSO, PAPEL (OPCIONAL)	1
	27	612769	LABEL, "2370"	AUFKLEBER	ÉTIQUETTE	LABEL	ADHESIVO	2
	28	1001193	AXLE, 5"DX14.72"LG	ACHSE	ESSIEU	AS	EJE	1
	29	140063	WASHER, .51X1.25X.312 FLT	SCHEIBE	RONDELLE	RING	ARANDELA	2
	30	4252	WASHER, COMP. 1/2	SCHEIBE	RONDELLE	RING	ARANDELA	2
	31	1001369	●WHEEL, 5.0DX1.25W	RAD	ROUE	WIEL	RUEDA	2
	32	103019	CAP, HUB	KAPPE	CAPUCHON	KAP	TAPA	2
	33	1005645	SHIELD, SKIRT	SCHILD	BOUCLIER	SCHERM	PROTECCIÓN	1
	34	1005629	●SKIRT, DUST CONTROL	SCHÜRZE	JUPE	SPATSCHORT	FALDILLA	1
∇	35	069767094	KIT, BAND REPLACEMENT	ABDECKBAND	BANDE	BAND	BANDA	1
▲	36	602044000AM	FASTENER, ADJ. SKIRT	VERSCHLÜSSE	ATTACHES	KLEM	SUJETADORES	1
	37	630613	STRIP, SKID	STREFEN	BANDE	STROOK	TIRA	1
	38	140350	SCREW, #10X1/2 PANPHL	SCHRAUBE	VIS	SCHROEF	TORNILLO	6
	39	600189	●CASTER, STEM	ZWENKRAD	ROULETTE	ZWENKWIEL	RUEDA ORIENTAL	1
	40	140509	NUT, JAM 1/2-13	MUTTER	ECROU	MOER	TUERCA	1
	41	1007686	HOUSING, BASE TEAL	GEHAUSE	BOITIER	BEHUIZING	CAJA	1
	42	1008479	BRACKET, SPRING MOUNT ADJ.	HALTER	SUPPORT	STEUN	SOPORTE	1
	43	10829	SCREW, 3/8-16X3/4 SCKT HD	SCHRAUBE	VIS	SCHROEF	TORNILLO	1
	44	140027	WASHER, FLAT .31	FLACHSCHEIBE	RONDELLE	VLAKRING	ARANDELA	3
	45	140015	WASHER, LOCK SPLIT	SCHEIBE	RONDELLE	SLUITRING	ARANDELA	3
	46	15675	SCREW, HEX M8X1.25X16	SCHRAUBE	VIS	SCHROEF	TORNILLO	3
	47	1007514	BRACKET, SPRING MOUNT FRT	HALTER	SUPPORT	STEUN	SOPORTE	1
	48	140028	WASHER, FLAT 3/8	FLACHSCHEIBE	RONDELLE	VLAKRING	ARANDELA	1
	49	36643	NUT, HEX LOCK .38-16	MUTTER	ECROU	MOER	TUERCA	2
	50	1007402	PLATE, SPRING MOUNT	PLATTE	PLAQUE	PLAAT	PLACA	1
	51	1008721	SPRING, EXT. 4.0LG	FEDER	RESSORT	VEER	RESORTE	2
	52	1008313	●CORD, BASE	KABEL	CABLE	STROOMKABEL	CABLE	1

∇ ASSEMBLY/BAUGRUPPE/ENSEMBLE/SAMENSTEL/CONJUNTO

▲ INCLUDED IN ASSEMBLY/IM BAUGRUPPE INBEGRIFFEN/Y COMPRIS EN ENSEMBLE/  
BIJ SAMENSTELLING INBEGREPEN/INCLUIDO A CONJUNTA

● RECOMMENDED STOCK ITEM/ EMPFOHLENER VORRATSARTIKEL/ ELÉMENTS DE STOCK RECOMMANDÉS/  
AANBEVOLEN ARTIKELN OP VOORRAAD/ PIEZAS RECOMENDADAS EN ALMACÉN

**PARTS LIST – ERSATZTEILLISTE – LISTE DES PIÈCES –  
 ONDERDELENLIJST – LISTA DE REPUESTOS**

**PAD DRIVER GROUP - PAD ANTIEB GRUPE - GROUPE ENTRAINEMENT DU PATIN  
 - BOENSCHIJF AANDRIJF GROEP - GRUPO TRANSMISIÓN DE ALMOHADILLA DE LIMPIEZA**

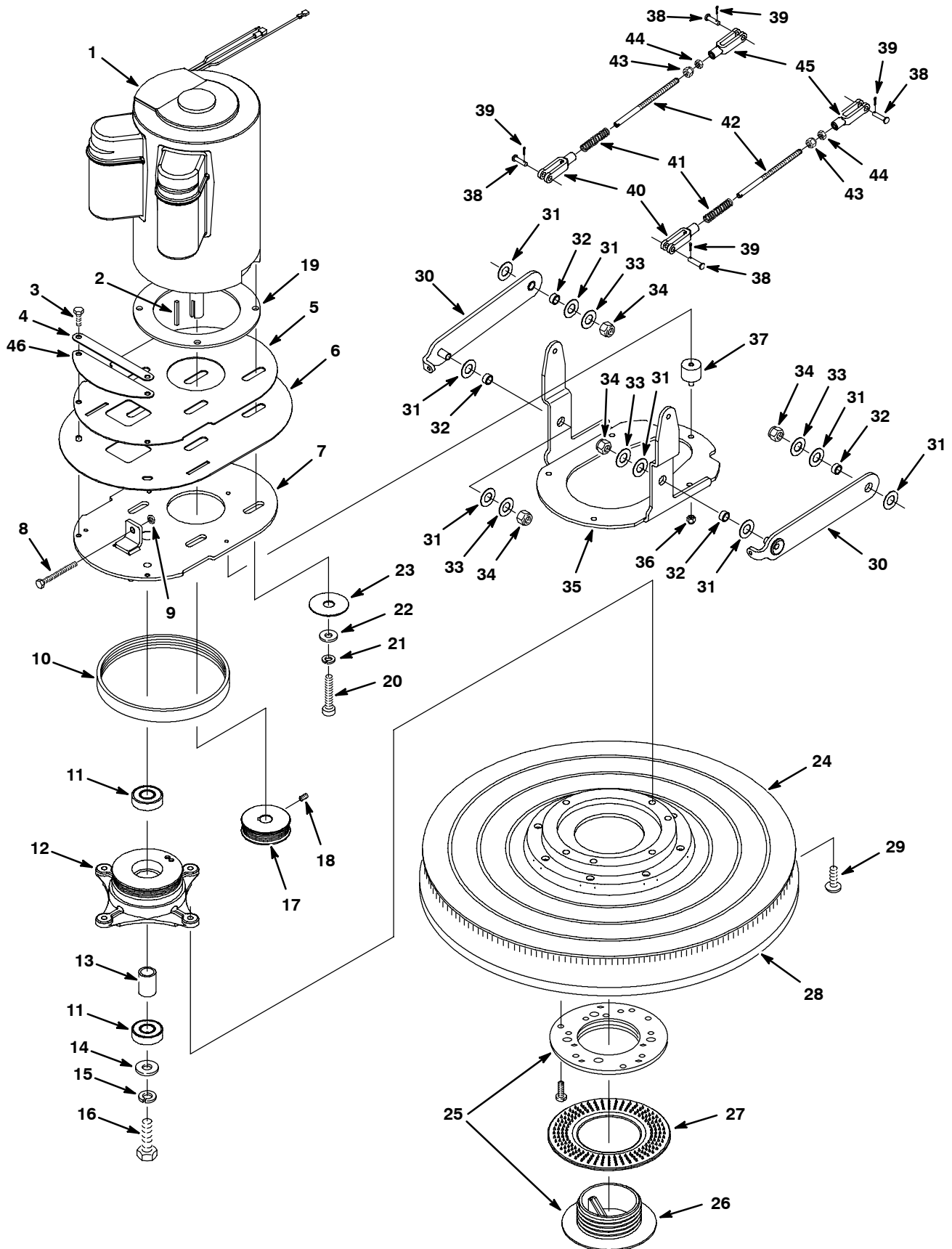



**PARTS LIST – ERSATZTEILLISTE – LISTE DES PIÈCES –  
ONDERDELENLIJST – LISTA DE REPUESTOS**

**PAD DRIVER GROUP - PAD ANTIEB GRUPPE - GROUPE ENTRAINEMENT DU PATIN  
- BOENSCHIJF AANDRIJF GROEP - GRUPO TRANSMISIÓN DE ALMOHADILLA DE LIMPIEZA**

REF	PART #	DESCRIPTION	BEZEICHNUNG	DESIGNATION	OMSCHRIJVING	DESCRIPCIÓN	QTY	
▽	1	1007584	●MOTOR, 230V/240V/50HZ (1700 & 2000RPM MODEL)	ELEKTROMOTOR	MOTEUR ÉLECTR.	ELEKTROMOTOR	ELECTROMOTOR	1
▲		1010544	CAPACITOR, 50 MED RUN	KONDENSATOR	CONDENSATEUR	CONDENSATOR	CONDENSADOR	1
▲		1010545	CAPACITOR, 340-408 MED START	KONDENSATOR	CONDENSATEUR	CONDENSATOR	CONDENSADOR	1
▲	2	140628	KEY, 3/16X1.0	SCHLÜSSEL	CLÉ	SLEUTEL	ILAVE	1
▽	1	1008736	●MOTOR, 220V/60HZ (2000RPM MODEL)	ELEKTROMOTOR	MOTEUR ÉLECTR.	ELEKTROMOTOR	ELECTROMOTOR	1
▲		1010547	CAPACITOR, 25 MED RUN	KONDENSATOR	CONDENSATEUR	CONDENSATOR	CONDENSADOR	1
▲		1010546	CAPACITOR, 540-648 MED START	KONDENSATOR	CONDENSATEUR	CONDENSATOR	CONDENSADOR	1
▲	2	140628	KEY, 3/16X1.0	SCHLÜSSEL	CLÉ	SLEUTEL	ILAVE	1
	3	200031432	SCREW, M6X1.0X10 HXHDCP	SCHRAUBE	VIS	SCHROEF	TORNILLO	2
	4	1010898	PLATE	PLATTE	PLAQUE	PLAAT	PLACA	1
	5	1007372	PLATE, RETAINER SEAL	PLATTE	PLAQUE	PLAAT	PLACA	1
	6	1006933	●SEAL, MOTOR MOUNT	DICHTRING	JOINT	AFDICHTING	RETÉN	1
	7	1006932	PLATE, MOTOR MOUNT	PLATTE	PLAQUE	PLAAT	PLACA	1
	8	200032503	SCREW M8X1.25X60 HXHD	SCHRAUBE	VIS	SCHROEF	TORNILLO	1
	9	200101017	NUT, M8 TENSIONER	MUTTER	ECROU	MOER	TUERCA	1
	10	1008604	●BELT, J6X15.75" (220V/60HZ 2000RPM & 230V/50HZ 1700RPM MODEL)	RIEMEN	COURROIE	RIEM	CORREA	1
		1008605	●BELT, J6X16.25" (230V/240V/50HZ 2000RPM MODEL)	RIEMEN	COURROIE	RIEM	CORREA	1
	11	140123	●BEARING, BALL	LAGERKUGEL	BILLE DE ROULEMENT	LAGERKOGEL	COJINETE DE BOLAS	2
	12	1006834	DRIVE, DRIVER	RIEMENSCHLEIBENHÄLFTE	POULIE	POELIE	DISCO	1
	13	230446	SPACER, 1.25L STEEL	ABSTANDSTÜCK	ENTRETOISE	AFSTANDSSTUK	SEPERADOR	1
	14	32492	WASHER, FLAT .38	FLACHSCHEIBE	RONDELLE	VLAKRING	ARANDELA	1
	15	140017	WASHER, LOCK SPLIT .38	SCHEIBE	RONDELLE	SLUITRING	ARANDELA	1
	16	02994	SCREW, HEX 3/8- 16X3/4	SCHRAUBE	VIS	SCHROEF	TORNILLO	1
	17	1006836	SHEAVE, 2.12"OD (220V/60HZ 2000RPM & 230V/50HZ 1700RPM MODEL)	RIEMENSCHLEIBENHÄLFTE	POULIE	POELIE	DISCO	1
	17	1006837	SHEAVE, 2.50"OD (230V/240V/50HZ 2000RPM MODEL)	RIEMENSCHLEIBENHÄLFTE	POULIE	POELIE	DISCO	1
	18	200252432	SCREW, SET M6	SCHRAUBE	VIS DE PRESSION	BEVESTIGINGSSCHROEF	TORNILLO DE FIJACIÓN	2
	19	1007309	●SPACER, MOTOR (220V/60HZ MOTOR ONLY)	ABSTANDSTÜCK	ENTRETOISE	AFSTANDSSTUK	SEPERADOR	1
	20	140847	SCREW, .38-16X1.00	SCHRAUBE	VIS	SCHROEF	TORNILLO	4
	21	140017	WASHER, LOCK SPLIT .38	SCHEIBE	RONDELLE	SLUITRING	ARANDELA	4
	22	140028	WASHER, FLAT .38	FLACHSCHEIBE	RONDELLE	VLAKRING	ARANDELA	4
	23	1008719	WASHER, .39IDX2.00DX.0359	FLACHSCHEIBE	RONDELLE	VLAKRING	ARANDELA	4
▽	24	1007472	●ASM., PAD DRIVER 20"	BAUGRUPPE	ENSEMBLE	SAMENSTEL	CONJUNTO	1
▲▽	25	25707	ASM., CENTERLOCK	SICHERUNGSRING	ANNEAU DE BLOCAGE	CENTERBORGRING	ANILLO DE CIERRE	1
▲	26	100101	RING, PAD RETAINER	HALTERING	ANNEAU D'ARR.	SLUITRING	ARO RETENCIÓN	1
	27	572084000	WASHER, PAD DRIVER	SCHEIBE	RONDELLE	RING	ARANDELA	1
	28	611788	●PAD, 20" HAIRBLEND BURNISH (1 CARTON = 5 PADS)	POLSTER	COUSSIN	BLOK	ALMOHADILLA	1
	29	1008753	SCREW, 5/16-18X1.125	SCHRAUBE	VIS	SCHROEF	TORNILLO	4
	30	1007660	BRACKET, MOTOR LIFT ARM	HALTER	SUPPORT	STEUN	SOPORTE	2
	31	20536-2	WASHER, FLT 0.47B 1.19D .03 NY	FLACHSCHEIBE	RONDELLE	VLAKRING	ARANDELA	8
	32	600191	BUSHING, 0.50DX0.23L STEEL	BÜCHSE	BAGUE	LAGERBUS	BUJE	4
	33	140028	WASHER, FLAT 3/8	FLACHSCHEIBE	RONDELLE	VLAKRING	ARANDELA	4
	34	36643	NUT, HEX LOCK 3/8-16 THIN	MUTTER	ECROU	MOER	TUERCA	4
	35	1007689	BRACKET, ISOLATOR	HALTER	SUPPORT	STEUN	SOPORTE	1
	36	140524	NUT, 1/4-20 KEP	MUTTER	ECROU	MOER	TUERCA	5
	37	1000409	MOUNT, VIBRATION	MOTORAUFHÄNGUNGEN	SUPPORTS DU MOTEUR	MOTORSTEUNEN	SOPORTES DEL MOTOR	5
	38	605070	PIN, CLEVIS	STIFT	GOUPILLE	PEN	PASADOR	4
	39	08170	PIN, COTTER	STIFT	GOUPILLE	PEN	PASADOR	4
	40	1008527	YOKE, W/O THREAD	GABELGELENK	CHAPE	VORK	HORQUILLA	2
	41	1008716	SPRING, COMP.	FEDER	RESSORT	VEER	RESORTE	2
	42	1008528	ROD	STANGE	BIELLE	STANG	VARILLA	2
	43	13513	NUT, 1/4-28 LOCK	MUTTER	ECROU	MOER	TUERCA	2
	44	607953	NUT, 1/4-28 JAM	MUTTER	ECROU	MOER	TUERCA	2
	45	605068	YOKE, W/THREAD	GABELGELENK	CHAPE	VORK	HORQUILLA	2
	46	1010897	SPACER, NEOPRENE	ABSTANDSTÜCK	ENTRETOISE	AFSTANDSSTUK	SEPERADOR	1

▽ ASSEMBLY/BAUGRUPPE/ENSEMBLE/SAMENSTEL/CONJUNTO

▲ INCLUDED IN ASSEMBLY/IM BAUGRUPPE INBEGRIFFEN/Y COMPRIS EN ENSEMBLE/

BIJ SAMENSTELLING INBEGREPEN/INCLUIDO A CONJUNTA

● RECOMMENDED STOCK ITEM/ EMPFOHLENER VORRATSARTIKEL/ ELÉMENTS DE STOCK RECOMMANDÉS/  
AANBEVOLEN ARTIKELN OP VOORRAAD/ PIEZAS RECOMENDADAS EN ALMACÉN

**ELECTRICAL DIAGRAM - ELEKTRISHERS SYSTEM - SYSTÈM ÉLECTRIQUE - ELEKTRISCH SYSTEEM - ESQUEMA ELÉCTRICO**

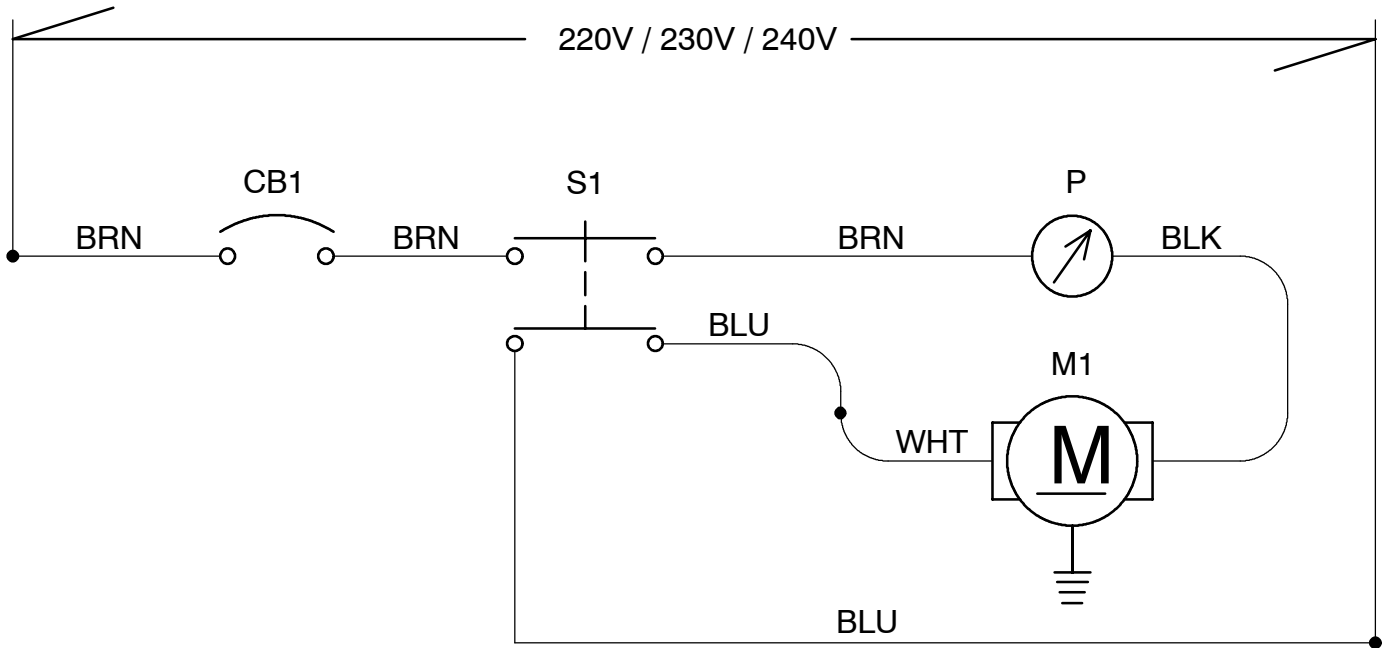

English REF	LEGEND
BLK =	Black
GRN =	Green
RED =	Red
WHT =	White
BLU =	Blue
ORG =	Orange
BRN =	Brown
TAN =	Tan
PNK =	Pink
YEL =	Yellow
Cb1 =	Breaker, Circuit 10a
M1 =	Motor, Pad
S1 =	Switch, Main
P =	Meter, Pad Pressure

Deutsch	SCHLÜSSEL
Schwarz	
Grün	
Rot	
Weiß	
Blau	
Orange	
Braun	
Tan	
Rosa	
Yellow	
Sicherungsautomat	
Motor	
Schalter	
Meter	

Français	LÉGENDE
Noir	
Vert	
Rouge	
Blanc	
Bleu	
Orange	
Brun	
Tan	
Rose	
Yellow	
Coupe-circuit	
Moteur	
Interrupteur	
Jauge	

Nederlands	LEGENDE
Zwart	
Groen	
Rood	
Wit	
Blauw	
Oranje	
Bruin	
Tan	
Rose	
Yellow	
Zekeringautomaat	
Motor	
Schakelaar	
Meter	

Español	LEYENDA
Negro	
Verde	
Rojo	
Blanco	
Azul	
Naranja	
Marron	
Tan	
Rosa	
Yellow	
Cortacircuitos	
Motor	
Interruptor	
Calibrador	